

INSTALLATION INSTRUCTIONS

C-2345, Multi Range Mini Split-Core 4-20mA Output

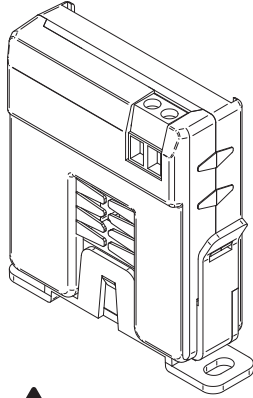

DANGER

Failure to follow these instructions will result in death or serious injury.



Hazard of electrical shock, explosion, and arc flash

- Follow ALL requirements in NFPA 70E for safe work practices and for Personal Protective Equipment (USA) and other applicable local codes when installing this product
- Only qualified electrical personnel should install this product.
- Read, understand, and follow all instructions thoroughly
- Install only on insulated conductors
- Lock out and tag out all power sources prior to installation. Use properly rated voltage sensing instrument to determine no voltage is present



WARNING

Failure to follow these instructions could result in death or serious injury.



Automated equipment may start without warning

- Equipment monitored/operated by this device may start without warning. Keep clear of apparatus at all times

IMPORTANT WARNINGS

- Only qualified trade installers should install this product
- This product is not intended for life-safety applications
- Do not install in hazardous or classified locations
- The installer is responsible for all applicable codes
- This product must be installed in a suitable electrical enclosure

INSTALLATION



Disconnect, lock out and tag out all power supplies during installation

1. Determine mounting location for the sensor near the conductor to be monitored. The sensor should be located AT LEAST 1/2" from any uninsulated conductor.
2. Sensor features a flexible iris which allows the sensor to hang on the conductor if local codes permit. A bracket is included for screw mounting or attaching to DIN rail. For screw mounting, drill two 3/32" pilot holes using the bracket as a template; ensure no drill shavings are present in enclosure. Attach bracket with screws provided.
3. Clamp sensor around INSULATED CONDUCTOR ONLY, 600VAC MAX to be monitored.
4. Snap the sensor into the mounting bracket.
5. Wire the output of the sensor to a control panel analog input. Sensor is loop-powered. 12 to 30vdc excitation required.

SETUP

1. Sensor is factory calibrated to three ranges. No field calibration is required.
2. Move selector switch to desired factory calibrated range setting. Selected range should be greater than the maximum motor current.

WIRING EXAMPLE

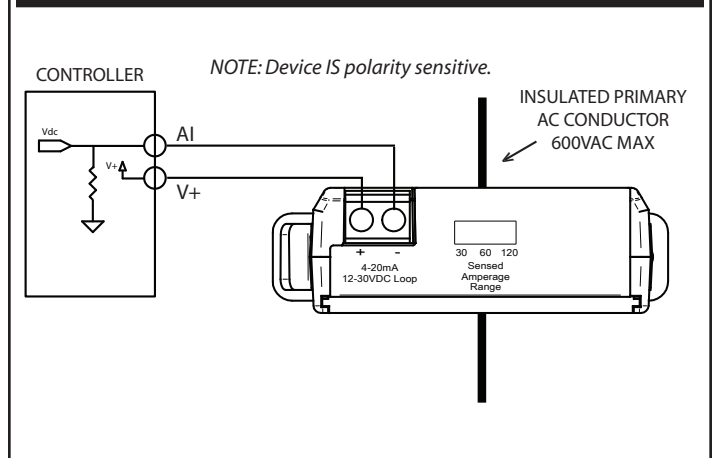

PRODUCT APPLICATION LIMITATION:

Senva products are not designed for life or safety applications. Senva products are not intended for use in critical applications such as nuclear facilities, human implantable device or life support. Senva is not liable, in whole or in part, for any claims or damages arising from such uses.

DIMENSIONS

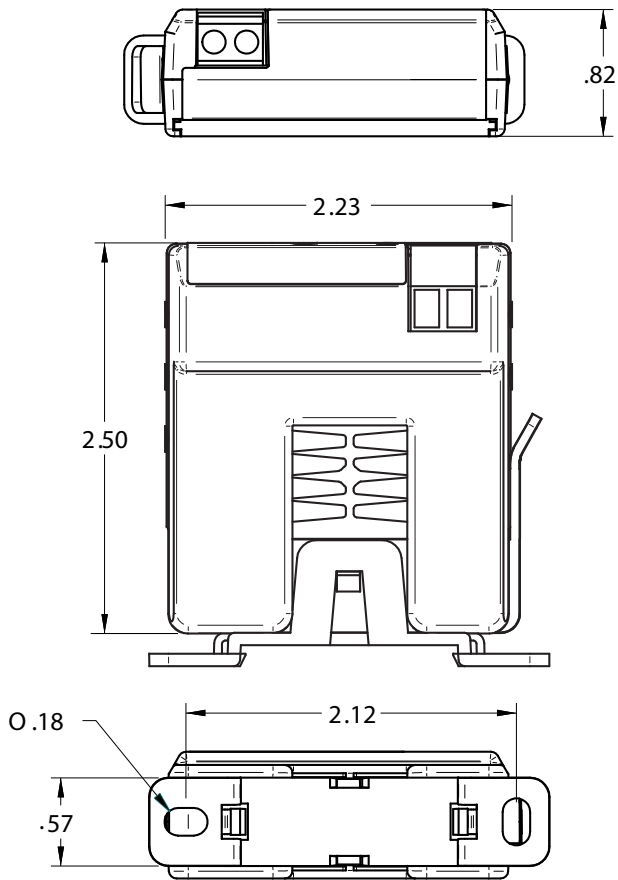

TECH TIPS

On low current loads, wrap sensor multiple times to increase sensitivity

CAUTION: Do not exceed sensor maximum current. The current detected by the sensor will increase 1X with each wrap.

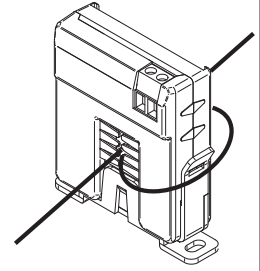

To monitor loads greater than the current sensor maximum rating

Use a properly rated 5A CT as shown below



CAUTION!

5A CTs can present hazardous voltages. Install CTs in accordance with manufacturers instructions. Terminate the CT secondary wiring before energizing primary conductor.

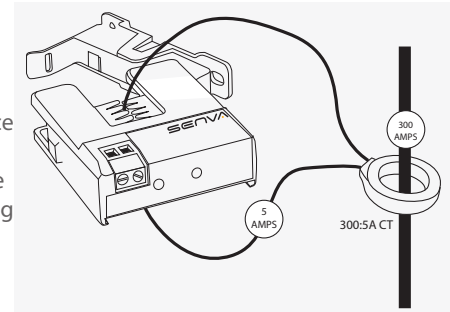

Remember to consider the ratio of the CT secondary to the sensor full-scale range to determine sensor output. Example: A 300:5A CT will produce 5 amps max, which is 1/6th of the 30 amp full-scale range of the C-2345. Applying this ratio (1/6) to the 16mA output range (20mA - 4mA) gives a 2.67mA signal change for a reading of 6.67mA at 300 A.

OPERATION

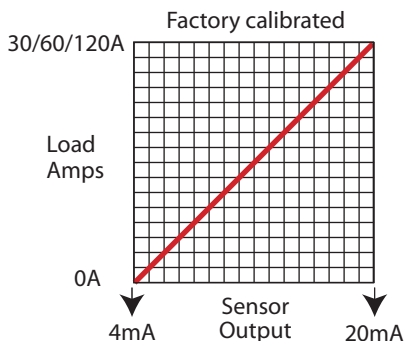

The C-2345 provides a 4-20mA output signal proportional to monitored current. A switch allows field selection of 30, 60, or 120 amps full-scale.

Typical load status applications include:

- Load trending
- Monitoring process motors and pumps
- Heater current monitoring

Troubleshooting

Symptom	Causes	Remedy
Sensor output is over 20mA	Amperage is above factory calibrated maximum	See Tech Tip for monitoring loads greater than current sensor maximum rating
No output current	No excitation voltage Backward wiring	Check excitation voltage Check polarity
Wrong output current	Incorrect scaling	Verify controller scaling

Part Number	C-2345
Amperage Range	Switch selectable 30/60/120 amps (200A Max.)
Output Type	4-20mA, loop powered
Accuracy	+/-2% F.S. over 10 to 100% range
Temperature Rating	-15~60 °C
Insulation Class	600V RMS. For use on insulated conductors only! Use minimum 75 °C insulated conductor
Sensor Power	12 to 30VDC Max.
Frequency Range	50/60Hz
Dimensions (LxWxH)	2.94" x 2.23" x 0.82" (1.4" H with optional relay module)
Sensor Aperture	0.75"