

INSTALLATION INSTRUCTIONS

C-1203, Analog Mini Solid-Core 0-5vdc Output

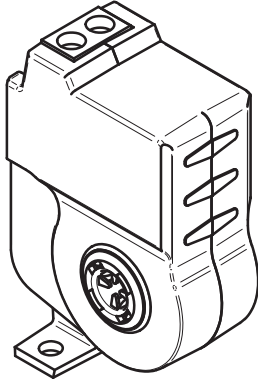

DANGER

Failure to follow these instructions will result in death or serious injury.



Hazard of electrical shock, explosion, and arc flash

- Follow ALL requirements in NFPA 70E for safe work practices and for Personal Protective Equipment (USA) and other applicable local codes when installing this product
- Only qualified electrical personnel should install this product.
- Read, understand, and follow all instructions thoroughly
- Install only on insulated conductors
- Lock out and tag out all power sources prior to installation. Use properly rated voltage sensing instrument to determine no voltage is present



WARNING

Failure to follow these instructions could result in death or serious injury.



Automated equipment may start without warning

- Equipment monitored/operated by this device may start without warning. Keep clear of apparatus at all times

IMPORTANT WARNINGS

- Only qualified trade installers should install this product
- This product is not intended for life-safety applications
- Do not install in hazardous or classified locations
- The installer is responsible for all applicable codes
- This product must be installed in a suitable electrical enclosure

SENAVA

INSTALLATION



Disconnect, lock out and tag out all power supplies during installation

1. Determine mounting location for the sensor near the conductor to be monitored. The sensor should be located AT LEAST 1/2" from any uninsulated conductor.
2. Drill a single 3/32" pilot hole for mounting the sensor; ensure no drill shavings are present in enclosure.
3. Thread INSULATED CONDUCTOR ONLY, 600VAC MAX to be monitored through the iris of the sensor.
4. Reconnect the conductor and torque appropriately.
5. Screw mount the sensor to the enclosure.
6. Wire the output of the sensor to a control panel analog input. Sensor is self powered. No excitation voltage needed.

WIRING EXAMPLE

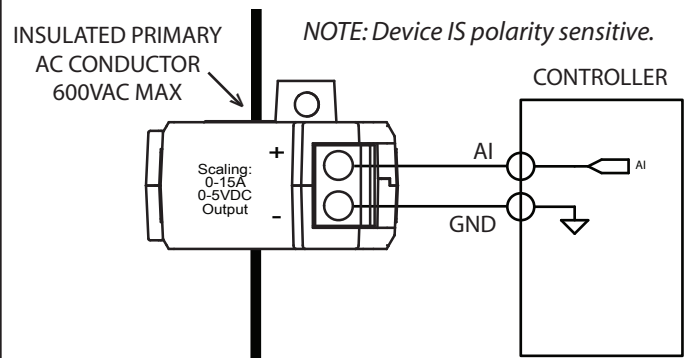

PRODUCT APPLICATION LIMITATION:

Senva products are not designed for life or safety applications. Senva products are not intended for use in critical applications such as nuclear facilities, human implantable device or life support. Senva is not liable, in whole or in part, for any claims or damages arising from such uses.

DIMENSIONS

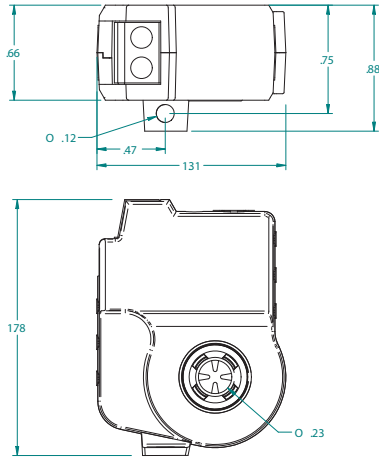

OPERATION

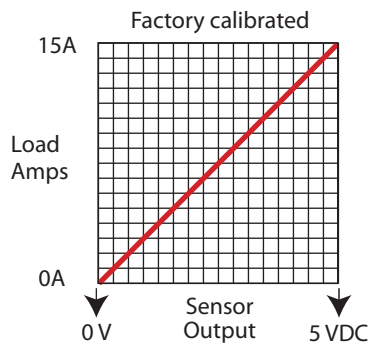

The C-1203 produces a 0 to 5 volt DC output proportional to monitored current up to 15 amps.

Typical current monitoring applications include:

- Load trending
- Monitoring process motors and pumps
- Heater current monitoring

TECH TIPS

Factory Calibration

Sensors are factory calibrated to within +/-2% accuracy from 10% to 100% of rated load. In some buildings, harmonics and noise caused by switching power supplies and other non-linear loads may affect readings.

To monitor loads greater than the current sensor maximum rating

Use a properly rated 5A CT as shown below



CAUTION!

5A CTs can present hazardous voltages. Install CTs in accordance with manufacturers instructions. Terminate the CT secondary wiring before energizing primary conductor.

Remember to consider the ratio of the CT secondary to the sensor full-scale range to determine sensor output. Example: A 200:5A CT will produce 5 amps max, which is 1/3 of the 15 amp full-scale range of the C-1203. Applying this ratio (1/3) to the 5 volt output gives 1.67VDC output at 200 A.

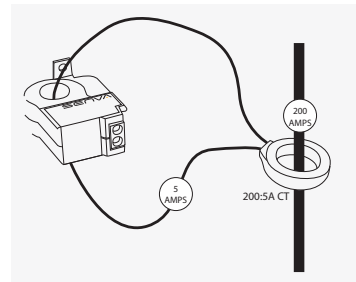

Troubleshooting

Symptom	Causes	Remedy
Sensor output is over 5 volts	Amperage is above factory calibrated maximum	See Tech Tip for monitoring loads greater than current sensor maximum rating
No output or wrong output voltage	Wiring error	Check polarity Check ground connection
	Incorrect scaling	Verify controller scaling

Part Number	C-1203
Amperage Range	0 ~15A (50A Max.)
Output Type	Self-Powered Voltage output 0-5VDC
Accuracy	+/-2% F.S. over 10 to 100% range
Temperature Rating	-15~60 ° C
Insulation Class	600V RMS. For use on insulated conductors only! Use minimum 75 ° C insulated conductor
Sensor Power	Induced
Frequency Range	50/60Hz
Dimensions (LxWxH)	1.78" x 1.32" x 0.66"
Sensor Aperture	0.30"