

# INSTALLATION INSTRUCTIONS

## C-1205, Analog Mini Solid-Core 4-20mA Output

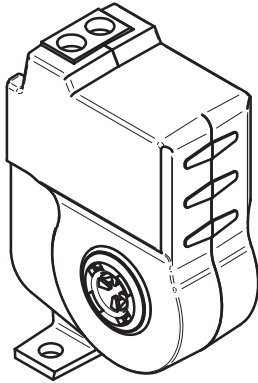

### DANGER

**Failure to follow these instructions will result in death or serious injury.**



Hazard of electrical shock, explosion, and arc flash

- Follow ALL requirements in NFPA 70E for safe work practices and for Personal Protective Equipment (USA) and other applicable local codes when installing this product
- Only qualified electrical personnel should install this product.
- Read, understand, and follow all instructions thoroughly
- Install only on insulated conductors
- Lock out and tag out all power sources prior to installation. Use properly rated voltage sensing instrument to determine no voltage is present



### WARNING

**Failure to follow these instructions could result in death or serious injury.**



Automated equipment may start without warning

- Equipment monitored/operated by this device may start without warning. Keep clear of apparatus at all times

### IMPORTANT WARNINGS

- Only qualified trade installers should install this product
- This product is not intended for life-safety applications
- Do not install in hazardous or classified locations
- The installer is responsible for all applicable codes
- This product must be installed in a suitable electrical enclosure



## INSTALLATION



Disconnect, lock out and tag out all power supplies during installation

1. Determine mounting location for the sensor near the conductor to be monitored. The sensor should be located AT LEAST 1/2" from any uninsulated conductor.
2. Drill a single 3/32" pilot hole for mounting the sensor; ensure no drill shavings are present in enclosure.
3. Thread INSULATED CONDUCTOR ONLY, 600VAC MAX to be monitored through the iris of the sensor.
4. Reconnect the conductor and torque appropriately.
5. Screw mount the sensor to the enclosure.
6. Wire the output of the sensor to excitation voltage, and control panel analog input. Sensor is loop-powered. 12 to 30VDC max. required.

## WIRING EXAMPLE

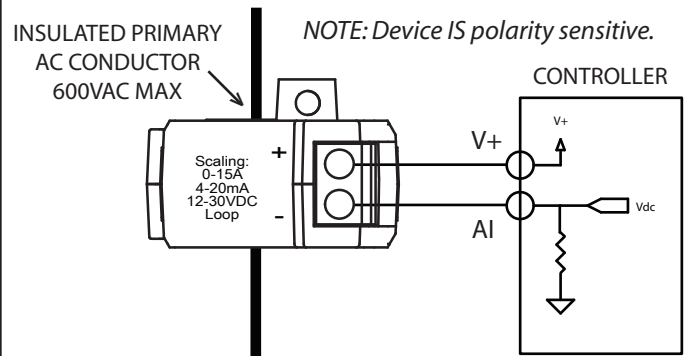

### PRODUCT APPLICATION LIMITATION:

Senva products are not designed for life or safety applications. Senva products are not intended for use in critical applications such as nuclear facilities, human implantable device or life support. Senva is not liable, in whole or in part, for any claims or damages arising from such uses.



## DIMENSIONS

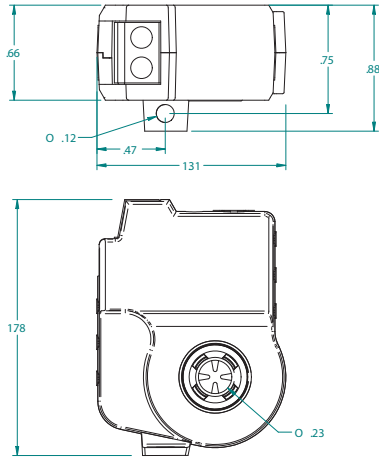

## OPERATION

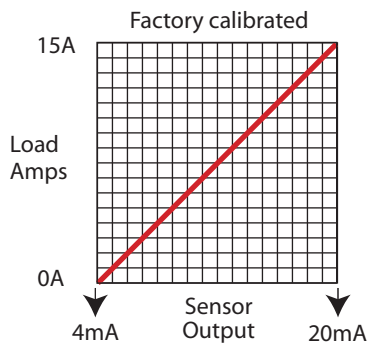

The C-1205 produces a loop-powered 4-20mA DC output proportional to monitored current up to 15 amps.

### Typical current monitoring applications include:

- Load trending
- Monitoring process motors and pumps
- Heater current monitoring

## TECH TIPS

### Factory Calibration

Sensors are factory calibrated to within +/-2% accuracy from 10% to 100% of rated load. In some buildings, harmonics and noise caused by switching power supplies and other non-linear loads may affect readings.

### To monitor loads greater than the current sensor maximum rating

Use a properly rated 5A CT as shown below



### CAUTION!

5A CTs can present hazardous voltages. Install CTs in accordance with manufacturers instructions. Terminate the CT secondary wiring before energizing primary conductor.

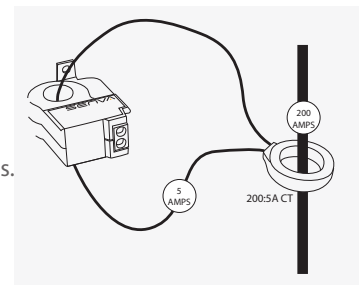

Remember to consider the ratio of the CT secondary to the sensor full-scale range to determine sensor output. Example: A 200:5A CT will produce 5 amps max, which is 1/3 of the 15 amp full-scale range of the C-1205. Applying this ratio (1/3) to the 16mA output range (20mA - 4mA) gives a 5.33mA signal change for a reading of 9.33mA at 200 A.

## Troubleshooting

Symptom	Causes	Remedy
Sensor output is over 20mA	Amperage is above factory calibrated maximum	See Tech Tip for monitoring loads greater than current sensor maximum rating
No output current	No excitation voltage Backward wiring	Check excitation voltage Check polarity
Wrong output current	Incorrect scaling	Verify controller scaling

Part Number	C-1205
Amperage Range	0 ~15A (50A Max.)
Output Type	4-20mA, loop powered
Accuracy	+/-2% F.S. over 10 to 100% range
Temperature Rating	-15~60 ° C
Insulation Class	600V RMS. For use on insulated conductors only! Use minimum 75 ° C insulated conductor
Sensor Power	12 to 30VDC Max.
Frequency Range	50/60Hz
Dimensions ( LxWxH)	1.78" x 1.32" x 0.66"
Sensor Aperture	0.30"