

INSTALLATION INSTRUCTIONS

HO-RF, Wireless Outside RH and RH/T Transmitters



IMPORTANT WARNINGS

- Only qualified trade installers should install this product
- This product is not intended for life-safety applications
- Do not install in hazardous or classified locations
- The installer is responsible for all applicable codes
- De-energize power supply prior to installation or service

DIMENSIONS

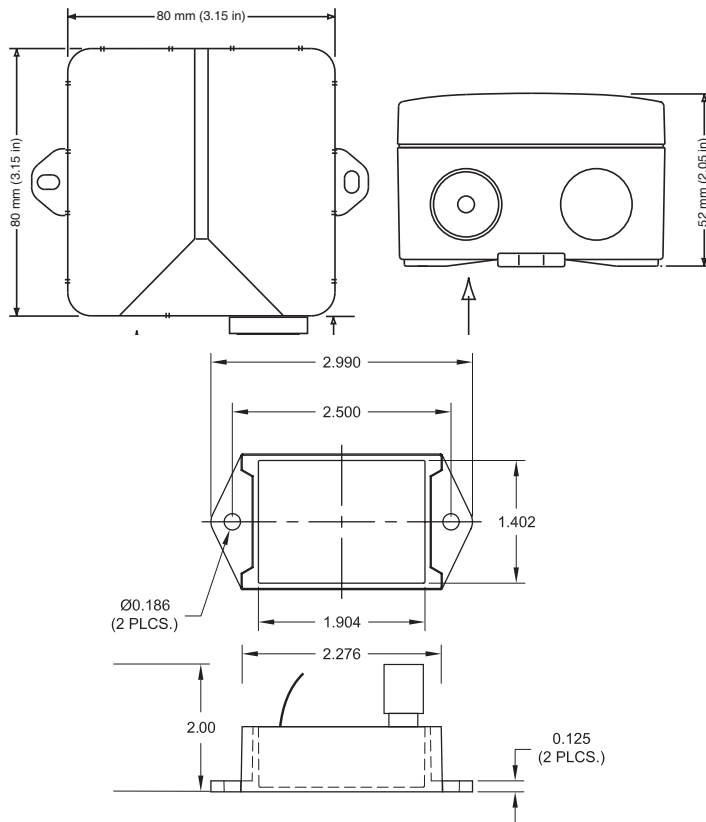

PRODUCT APPLICATION LIMITATION:

Senva products are not designed for life or safety applications. Senva products are not intended for use in critical applications such as nuclear facilities, human implantable device or life support. Senva is not liable, in whole or in part, for any claims or damages arising from such uses.

INSTALLATION - SENSOR

1. Locate sensor outside under eave on north side of building to prevent excessive solar heating and exposure to rain.
2. Secure enclosure to building.
3. Remove cover and move jumper as shown to power unit on.

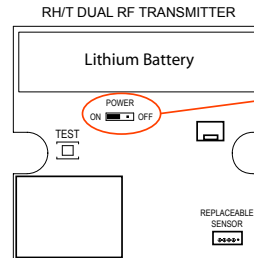

IMPORTANT!

To maximize battery life and to comply with transportation regulations, power jumper must be in off position for shipping.

Device utilizes a long-life, rechargeable battery. Consult factory for replacement battery and recycling instructions.

INSTALLATION - RECEIVER

1. Locate receiver as close as possible to sensor for best results. Normal radio range is 300' line of sight. Obstructions will reduce range. Do NOT install receiver in metal enclosure.

2. Wire receiver as shown:

VIN = Power supply +
 GND = Power and signal common
 RH - RH output, 0-10v
 T = Temperature output, 0-10v

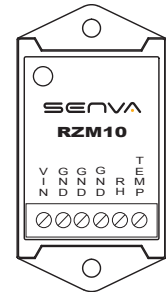

SETUP

Verify sensor power jumper is set to "on".

Verify receiver is wired correctly and powered.

Verify control panel is programmed with correct scaling:

RH scaling: 0-100% RH = 0-10v (RH * 10)
 T scaling: -40 to 140°F = 0-10v (T * 18) - 40

Press "TEST" button on sensor. LED will blink if receiver is in range and powered on.

OPERATION

Sensor is factory programmed to broadcast RH and Temperature updates every 5-minutes when sunlight is sufficient for battery charging. Broadcast interval increases to 30-minutes in dark and significantly shaded or overcast conditions.

Receiver will "hold" the last received update for up to 60-minutes. If no new update is received, outputs will revert to 0-volts to indicate a fault. Subsequent updates will resume normal receiver operation.

SPECIFICATIONS

Power supply	Transmitter Receiver	Internal battery; integral solar charger 12-30vdc/12vac ⁽¹⁾ , 45mA max.
Radio	Frequency/Power	2.4GHz unlicensed ISM band, ZigBee™, 60mW
	Range	300' line-of-sight
	FCC id	OUR24XBEE
	Broadcast interval	Daylight, 5-min; Dark, 30-min
Outputs (receiver)	RH and Temperature (option)	0-10vdc
Output scaling	RH	0-100%RH
	Temperature	-40-140 °F (-40-60°C)
Media filter		Stainless screen mesh in louvered vent plug
Relative Humidity	Accuracy	2% models, +/-2% over 10 to 90% range
		3% models, +/-3% over 20 to 80% range
	Resolution	0.05%RH
	Hysteresis	+/-1%RH
	Non-linearity	Factory linearized <1%RH
	Temperature coefficient	Fully compensated by on-board sensor
	Response time ⁽²⁾	30s
	Operating range	0 to 100%RH
	Long term drift	<0.5%RH per year
	Operating conditions ⁽³⁾	-20 to 60°C @ RH >90%
-20 to 80°C @ RH = 50%		
Temperature	Accuracy, (-20 to 70oC range)	2% models, <+/-1°C; 0.5°C typ@25°C
		3% models, <+/-2°C; 0.5°C typ@25°C
	Resolution	0.01°C
	Repeatability	+/-0.1°C
	Response time ⁽²⁾	30s
	Operating range	-40 to 120°C (sensor only)

(1) One side of transformer secondary is connected to signal common. Dedicated 12-volt transformer is recommended.

(2) Time for reaching 63% of reading at 25oC and 1 m/s airflow. Sensor only. Receiver updates at broadcast rate.

(3) Long term exposures to conditions outside normal range or high humidity may temporarily offset the RH reading (+3%RH after 60 hours.)

TROUBLESHOOTING

Symptom	Solution	Symptom	Solution
No output	Check wiring. Ensure power supply meets requirements.	Temp or RH reading error	Verify control panel software is configured for correct output scaling.
	Verify receiver is in range of sensor.		Verify unit is located out of direct sunlight.
	Verify sensor power jumper is set to "ON"	Sensor damage, contamination, or long-term drift	Replace sensor element. Consult factory for ordering information.
	Interference from radio, television, and cell-phone broadcast towers may reduce range.		