

INSTALLATION INSTRUCTIONS

TG SERIES

Toxic Gas Sensor

BACnet/Modbus/Analog



Use installation wires rated for 75°C and above.

The TG Series (the equipment covered by the IFU) has not been tested for Life Safety Applications and are not to be used in Life Safety Applications in jurisdictions that require this certification.

- Only qualified trade installers should install, program, maintain and test system incorporated therein. Installer is responsible for compliance of all applicable codes.
- Read, understand, and follow instructions thoroughly.
- The unit and associated systems require routine test and maintenance as prescribed in the TG Series User's Manual section 'Periodic Test and Maintenance'
- Do not install in hazardous or classified locations.
- De-energize power supply prior to installation.
- Gas sensors should not be used as a substitute for proper installation, use, or maintenance of gas emitting equipment.
- This device is designed to detect conditions that could result in acute effects of gas exposure. It will not fully safeguard individuals with specific medical conditions. If in doubt, consult a medical practitioner.
- Conduit is prone to condensation if it passes from one temperature zone to another, such as from indoors to outdoors or from one part of a building to another. This condensation may actually drip into the sensor if mounted below, causing damage and/or poor readings.

In order to prevent condensation and water egress, seal both the top and bottom of the conduit with a suitable expanding foam product (such as Polywater™ Zipseal™ ZIP-50KIT1) to prevent warm air from entering cold conduit.

Alternatively, fiberglass insulation may be inserted in the conduit between the cold and warm sections using a rigid wire or other method if both ends cannot be sealed. Sealing is the preferred method.

- Conduit air flow entering sensor may prevent sensor from reading ambient air properly, resulting in under measurement of gases. Plug sensor conduit in all installations with a foam plug or seal as noted above in order to prevent airflow from the conduit.

LIMITATION OF LIABILITY

Senva's liability, whether in contract, in tort, under any warranty, in negligence or otherwise shall not exceed the amount of the purchase price paid by the purchaser for the product. Under no circumstances shall Senva be liable for special or consequential damages.

TG <input type="checkbox"/>	-	<input type="checkbox"/>	<input type="checkbox"/>	-	<input type="checkbox"/>	<input type="checkbox"/>				
Package		Output Type		Gas Type 1*		Gas Type 2*		Temperature		Enclosure Lid
W = Wall Mount D = Duct Mount M = Metal		A = Analog B = BACnet/Modbus		C = Carbon Monoxide (CO) N = Nitrogen Dioxide (NO ₂) D = Carbon Dioxide (CO ₂) E = Dual Channel CO ₂ M = Methane (CH ₄) P = Propane (C ₃ H ₈) H = Hydrogen (H ₂) O = Oxygen (O ₂) S = Hydrogen Sulphide (H ₂ S) A = Ammonia (NH ₃) 2 = R22 3 = R134A (Multi-Refrigerant) 4 = R410A 5 = R404A 6 = R407C 7 = R449A 8 = R513A 9 = 1233ZDE		X = No second gas N = Nitrogen Dioxide (NO ₂) D = Carbon Dioxide (CO ₂) E = Dual Channel CO ₂ M = Methane (CH ₄) P = Propane (C ₃ H ₈) H = Hydrogen (H ₂) O = Oxygen (O ₂) S = Hydrogen Sulphide (H ₂ S) A = Ammonia (NH ₃)		A = None C = 100Pt RTD D = 1000Pt RTD E = 10K Type 2 F = 10K Type 3 G = 10k w/11k H = 3k I = 2k2 J = 1k8 K = 20k		Blank = Clear/Tinted S = Solid/Opaque W=White/Solid F = Fail Open

*Refrigerant sensors may not be paired with CH₄, C₃H₈, or H₂, or paired together.

TG <input type="checkbox"/>	-	REM	-	<input type="checkbox"/>
Package				Cable Length
W = Wall Mount M = Metal				5 = 5 feet 10 = 10 feet 15 = 15 feet 20 = 20 feet

INSTALLATION

1. Identify the package type (wall/metal or duct) of the TG Series sensor. Follow the 'Wall Mount' or 'Duct Mount' installation instructions accordingly:

Wall Mount (TGM or TGW)

Locate sensor near traffic areas, away from sources of ventilation or drafts. One sensor per 5000-7500 square feet is normally required (applies to CO, NO₂, CO₂, Methane, Hydrogen, Oxygen, H₂S, and Ammonia NH₃). Propane and refrigerant sensors should be limited to 5000 square feet or less.

Recommended CO, NO₂, CO₂, Oxygen, and H₂S Sensor Mounting Height is 3-6 feet above finished floor. Methane, Hydrogen, and Ammonia NH₃ sensors should be mounted within 1 foot of the ceiling. Propane sensors should be mounted 1-3 feet above the floor. Refrigerant sensors should be mounted 6 inches above floor. Check with local and state building codes to ensure sensor mounting height is in compliance.

Mount the sensor directly and securely to the wall with the fasteners best suited to your construction. Use the factory provided #8 x 3/4" Pan self tapping screws or equivalent.

- There are two mounting tabs for securing/mounting the sensor. Mount/secure sensor to desired position on the wall with screws while being careful not to over-tighten.
- The sensor has a hole in the back for mounting into a wall or a junction box. If a top mounted conduit connection is desired, drill out either of the top knockouts and install appropriate conduit fitting/connector.



ATTENTION: For conduit installations, remove circuit board from enclosure prior to drilling holes to ensure product is not damaged.

STREAMLINED WALL INSTALLATION

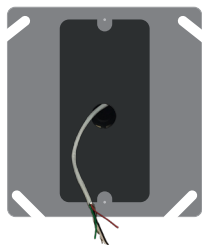

Step 1: Install mud plate in a 2x4" conduit junction box, or skip this step if mounting TG directly to wall

Step 2: Run wire(s) through TG center; mount TG

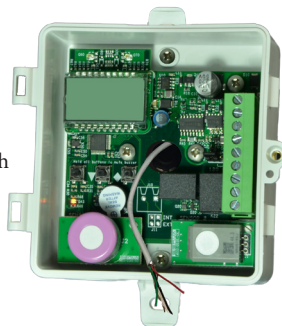

Step 3: Wire to removable terminal block, plug, and play



Remote Mount TGW-REM, TGM-REM

For installations that require separate mounting heights, the TGx-REM kit provides an easy solution. The TGx-REM comes with a pre-cut length of RJ45 cable, a plug-and-play sensor extension board, and a secondary TGW or TGM box equipped with everything you need to simply move one sensor board to a separate location.

For remote sensor, follow "wall mount" instructions to mount the enclosure at the height required.

1. From the primary TG (with LCD), remove the sensor board in the rightmost position and replace it with sensor extender board provided in the TG-REM kit.

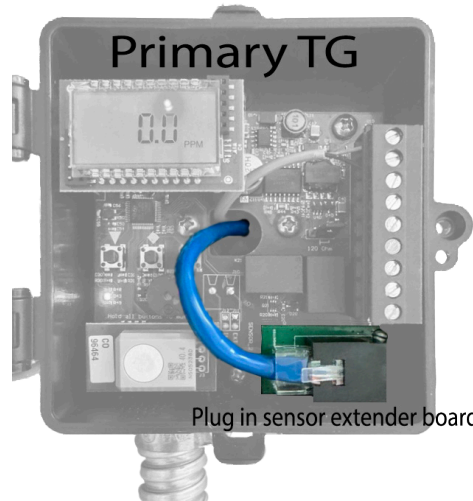

Un-plug remote sensor element

Plug in sensor extender board

2. Plug the removed sensor board into the TG-REM board using the provided red sensor connectors.

3. Run provided RJ45 cable between the two enclosures and plug each end into the provided sensor boards.

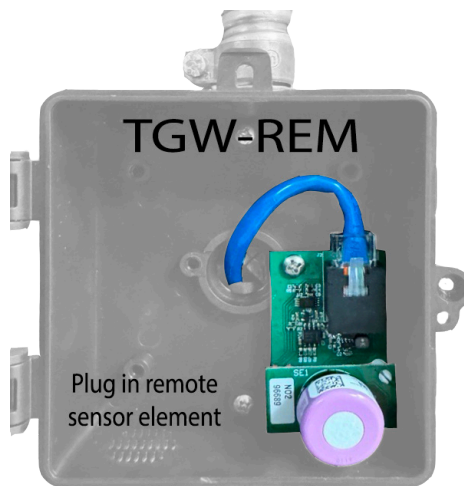

Plug in remote sensor element

For calibration, use the LCD on the primary TG. Alternatively, you may plug the remote sensor back into the primary TG to calibrate locally.

Note: Refrigerant and Catalytic sensors installed in the REM kit must be re-zeroed to correct the GND shift caused by inductors that are present to mitigate noise on the RJ45 cable.

INSTALLATION (Continued)

Duct Mount (TGD)

1. Drill a 3/4" hole in duct. Install sensor using gasket and screws provided. The pickup tube will ensure adequate air flow regardless of air flow direction.

Mount unit to duct with supplied screws.

2. Review the wiring call-outs and wire sensor to needed Inputs and outputs for your application. See *Page 4* for example wiring schematics.

3. For Bacnet/Modbus version, communication wires may be daisy chained and termination resistor may be utilized. Use of appropriate shielded twisted pair wire (14-26 AWG) is recommended, per protocol specifications. Total wiring runs should not exceed 4000 feet, with a maximum of 128 devices (BACnet) or 32 devices (Modbus) in a single daisy chain. Depending on the network configuration, it may be necessary to use the built in EOL (end-of-line) termination resistors on the TG Sensor. The below shows an enabled termination resistor.

EOL 120Ω Resistor

120Ω Bus termination resistor 

4. For applications utilizing the fan relay, the diagram on the following page shows connections between one or multiple TG sensors wired to an exhaust fan coil using the fan set-point relay(s). This function can be performed by a single TG sensor or a sequence of multiple TG sensors wired in parallel.

Ensure that the fan relay set-points are uniform. The fan relays will activate if one or more of the sensors reach the set-point.

5. Connect power wires. Use of a Class 2 LPS power supply or greater is required. Dedicated isolation transformers or power supplies are recommended for each sensor that is installed as shown in the schematic. Apply 15-30VDC or 24VAC to the V+ and V- terminals with appropriate sized wires (14-24AWG).

6. Apply power. Sensor may require up to 2 minutes of warm-up time prior to displaying valid gas measurements.

7. For Bacnet/Modbus version, connect the TG Sensor(s) to an active network. The Senva TG Series can be used on both BACnet and Modbus networks. The default settings on the sensor include auto-detection of protocol type, device address (BACnet only), serial format and baud rate. Each BACnet/Modbus TG sensor ships with a default Modbus address. This process is further detailed in the respective *TG BACnet Protocol Guide* or *TG Modbus Protocol Guide*. To manually adjust these parameters, utilize the *TG Series User's Guide*.

WIRING & CALLOUTS

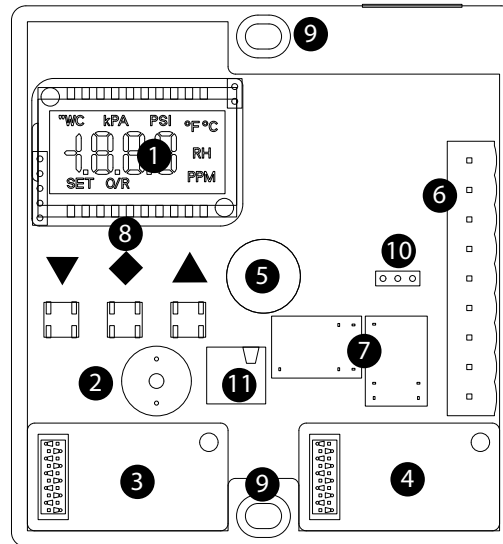

- 1 - LCD Display
- 2 - Buzzer
- 3 - Sensor Element 1
- 4 - Sensor Element 2
- 5 - Enclosure Hole for Wiring
- 6 - Terminal Block for Power and Control Wiring
- 7 - Fan and Alarm Relays
- 8 - Up/Down/Select Push Buttons
- 9 - Enclosure Mounting Holes
- 10 - EOL termination resistor
- 11 - Terminal Block for Thermistor Wiring

BACNet/Modbus
Version

POWER(+)
COMMON(±)
RS485(+) *
Agnd (↓) **
RS485(-) ***
FAN IN(F↔)
FAN OUT(F↔)
ALARM IN(A↔)
ALARM OUT(A↔)

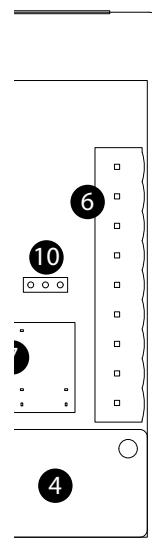

Analog Version

POWER(+)
COMMON(±)
Analog out 1 (O1)
Analog out 2 (O2)
Not used (NC)
FAN IN(F↔)
FAN OUT(F↔)
ALARM IN(A↔)
ALARM OUT(A↔)

WIRING EXAMPLES

Relay and BACnet Wiring - Standard relays

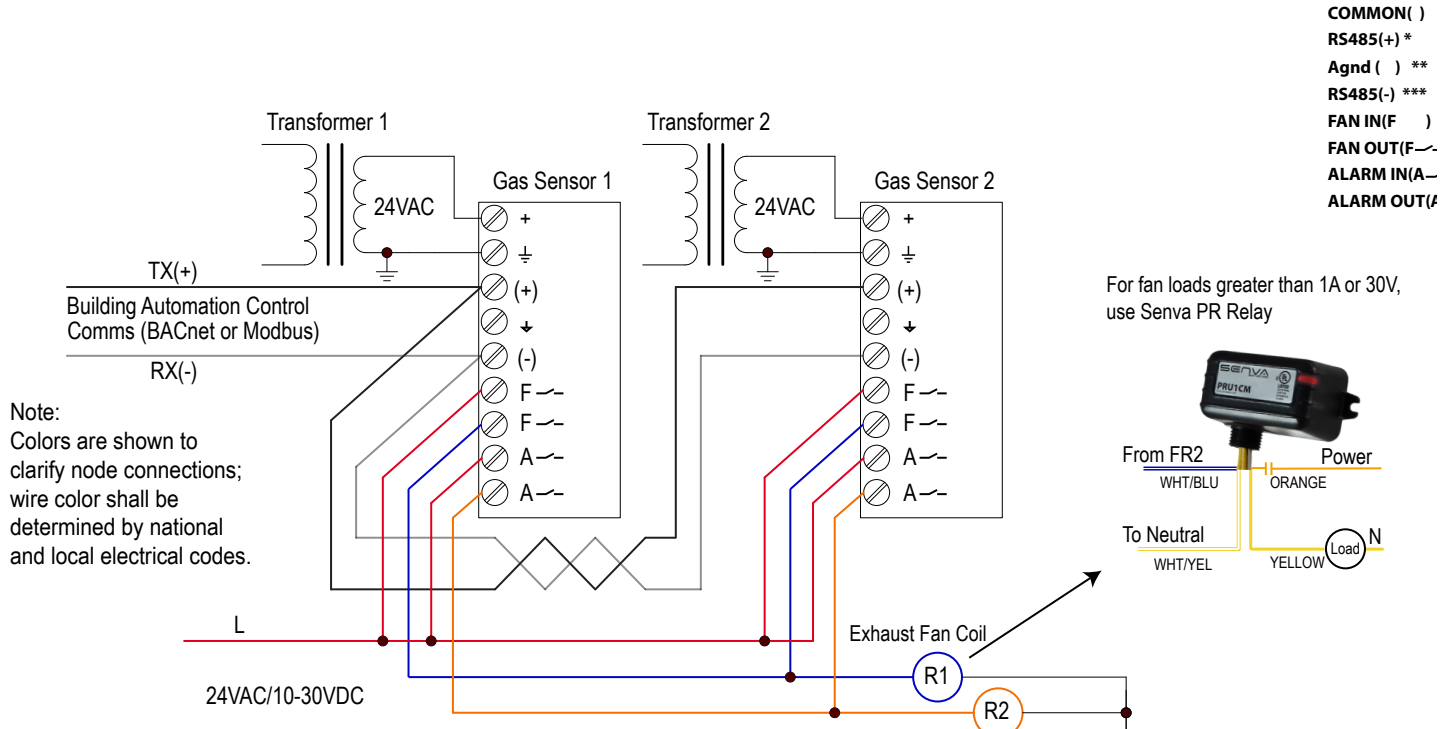

Analog Wiring for 0-5/10V circuits

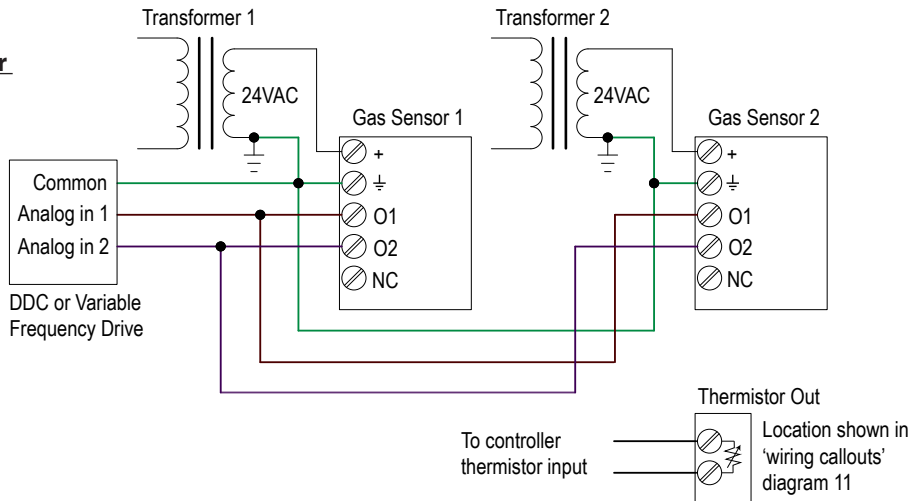

TESTING MENU

To ensure device wiring a testing menu is available.

Access this menu by pressing the **◆** and **▼** buttons simultaneously for one second. The settings

menu is organized into several categories.

- TEST** - Allows the user to set the testing interval
- OUT** - Allows the user to force the output signal to its highest value.
- FAN** - Allows the user to turn on the Fan relay for the length of the testing interval.
- ALM** - Allows the user to turn on the Alarm relay for the length of the testing interval.
- BZZ** - Allows the user to turn on the Piezo Buzzer for the length of the testing interval.

For more detailed instructions use this QR code to access our TG Series Users Guide.



OPERATION

The following section details factory defaults for LCD function, LED function, fan and alarm set-points, fan relay and alarm status functions, and the sensor element lifetime clock. These values can be modified from their default settings via the *TG Series User's Guide*.

LCD Function

The LCD is factory defaulted to toggle between readouts for each gas type populated on the board. Toggling can be modified using the *TG Series User's Guide*.

LED Function

The LED indicators function in sync with the fan relay and alarm status thresholds. LEDs will change state if either of the gases reach their fan or alarm set-point.

Green	Normal readings below the fan set-point
Yellow	Gas concentration above the fan set-point and below the alarm set-point
Red	Gas concentration level above the alarm set-point

Fan and Alarm Set-points

The fan and alarm set-points are only applicable for elements populated on the board by the factory, or added in the field by the user.

Sensor	Fan Relay (Default)	Alarm (Default)
CO	25 ppm	100 ppm
NO2	1 ppm	3 ppm
CO2	800 ppm	5000 ppm
Methane/ Propane/ Hydrogen	5% L.E.L.	10% L.E.L.
Oxygen	Less than 19.5% Vol	Greater than 23% Vol
H2S	25 ppm	75 ppm
Ammonia	20 ppm	40 ppm
Refrigerants	300 ppm	600 ppm

Fan Relay/Alarm Status - Standard relay option

Both the fan relay and alarm status are tied to the function of the LED indicators on each TG Series sensor. If a device has two elements populated on the board, then the fan relay and alarm status functions will activate if either of the gases reach their fan or alarm set-point.

Status	LED	Fan Relay	Alarm Relay	Audible Alarm
Off	-	Closed	Closed	Silent
Below Fan Set-point*	Green*	Open*	Open	Silent
Above Fan Set-point*	Yellow*	Closed*	Open	Silent
Above Alarm Set-point	Red	Closed	Closed	Silent
Above Alarm Set-point for 30 minutes (or user defined delay)	Red	Closed	Closed	On**

*For Oxygen, if reading is *below* fan setpoint, fan relay will close and *red LED* will be lit. *Above* the fan setpoint, the fan relay will open and green LED will be lit. **If Oxygen reading is *below* Fan setpoint for 30 minutes, audible alarm will activate.

Fan Relay/Alarm Status - Fail-open relay option

If the Fail-Open version of the TG is selected, the relay functionality will be completely reversed, as shown in the following table. The LEDs and Buzzer functionality will not change.

Status	LED	Fan Relay	Alarm Relay	Audible Alarm
Off	-	Open	Open	Silent
Below Fan Set-point*	Green*	Closed*	Closed	Silent
Above Fan Set-point*	Yellow*	Open*	Closed	Silent
Above Alarm Set-point	Red	Open	Open	Silent
Above Alarm Set-point for 30 minutes (or user defined delay)	Red	Open	Open	On**

*For Oxygen, if reading is *below* fan setpoint, fan relay will open and *red LED* will be lit. *Above* the fan setpoint, the fan relay will close and green LED will be lit. **If Oxygen reading is *below* Fan setpoint for 30 minutes, audible alarm will activate.

Self-Test Feature

If "pulse check" is activated in S1/S2 or via communications, unit will periodically check the health of installed sensor elements. If either installed sensor fails the check or the 7 year lifetime of the sensor is exceeded, buzzer will chirp every 60 seconds and a red LED will blink to indicate the sensor needs to be replaced. The duration of the fan relay and alarm buzzer operation are as follows. These values can also be modified from their default settings via the *TG Series User's Guide*.

Relay Activation Timing	
Fan Relay	Value
Minimum ON time	60 seconds
Minimum OFF time	60 seconds
Maximum OFF time	0 (inactive)
Audible Alarm Activation Timing	
Buzzer	Value
Delay	30 minutes
Minimum ON time	0 seconds
Minimum OFF time	0 seconds

Sensor Element Lifetime Clock

With 30 days remaining on the element life-cycle, the green LED will blink once every 10 seconds and the audible alarm will chirp once every 60 seconds. This timer can be viewed using the *TG Series User's Guide*. Contact factory for replacement elements or see *TG Series Calibration Guide* to field calibrate the sensor.

BACnet/Modbus Quick Reference

The following section outlines some commonly utilized Modbus registers and BACnet objects for quick reference. For a complete list and description of each, please see the associated protocol guides: *TG BACnet Protocol Guide* or *TG Modbus Protocol Guide*.

Access Legend:

R=Readable

W=Write-able

W0 = Write-able with 0 only

NV = Saved in non-volatile configuration memory

Description	BACnet Object	Modbus Register	Access
Temperature	AI310	R310/11	R/W0
Gas 1 Concentration	AI320	R320/21	R/W0
Gas 2 Concentration	AI330	R330/31	R/W0
Gas 1 Warning Set-point	AV150	R150	R/W/NV
Gas 1 Alarm Set-point	AV152	R152	R/W/NV
Gas 2 Warning Set-point	AV160	R160	R/W/NV
Gas 2 Alarm Set-point	AV162	R162	R/W/NV
Sensor 1 Self-Test Mode	BV196	R196	R/W/NV
Sensor 2 Self-Test Mode	BV197	R197	R/W/NV
Description	BACnet Object	Modbus Register	Data Type
Fan Relay	BO210(R/W)	R210(R)	BOOL
Fan Relay Override		R211(W)	UINT16
Alarm Relay	BO220(R/W)	R221(R)	BOOL
Alarm Buzzer	BO230(R/W)	R230(R)	BOOL
Alarm Buzzer Override		R231(W)	UNIT16

Supported Modbus Functions:

0x03 Read Holding Registers

0x06 Write Single Register

0x10 Write multiple Registers

PERIODIC TEST AND MAINTENANCE

Periodic Maintenance

Though the frequency of inspection is typically affected by the operating conditions and environment (extreme temperatures, extreme humidity, exposure to contaminants, etc.), Senva recommends the following maintenance and intervals. More frequent maintenance may be required per local code by the Jurisdiction Having Authority (JHA). An accurate log of all maintenance and abnormal occurrences should be maintained for the proper service of this product

Every 6 Months

- For H2S, Ammonia NH3 or refrigerants retest and recalibrate the unit using NIST traceable reference gas to ensure sensors remain accurate.
- Visually inspect to ensure optimal operating conditions (no broken pieces/components, sensor filter not blocked or discolored, visual indicators operational, etc.).
- Clean the exterior with a soft cloth to remove debris from the sensor intake ports.

Annual

- For Methane, Propane, and Hydrogen, it is recommended to conduct an annual bump test to confirm the sensor's responsiveness. A bump test involves exposing the sensor to a reference gas and detecting the sensor's response. If sensor response is out of accuracy range, recalibration or replacement of the sensor element may be necessary.
- For Oxygen, CO or NO2, retest and recalibrate the unit using NIST traceable reference gas to ensure sensors remain accurate.
- For sensor replacement be sure to power down the sensor and remove element to be replaced and plug in new element in its place and then re-apply power.

Do Not

- Expose the sensor to high pressure water spray.
- Expose the sensor and its elements to solvents.
- Immerse the sensor into liquids.

SPECIFICATIONS (Part 1/3)

Power supply	Power	15-30VDC/24VAC ⁽¹⁾ , 50/60Hz, 4w max, 160mA max.
Wiring	Conductor	14-24 AWG, Minimum 600V, 75°C
	Terminal Torque	0.5 N•m
Outputs (Analog)	2 Programmable Outputs	0-10V (default), 0-5V, 1-5V, 3-wire 4-20mA (menu selectable)
	CO Output Scaling	0-200ppm (default), 0-1000ppm (menu selectable)
	NO₂ Output Scaling	0-10ppm (default), 0-30ppm (menu selectable)
	CO₂ Output Scaling	0-10,000 ppm (default), 0-10,000 ppm (menu selectable)
	Propane/Methane/Hydrogen Output Scaling	0-50% LEL (default), 0-50% LEL (menu selectable)
	Oxygen Output Scaling	0-25% Vol (default), 0-25% Vol (menu selectable)
	Refrigerant Output Scaling	0-1000 ppm (default), 0-1000 ppm (menu selectable)
	H₂S Output Scaling	0-100 ppm (default), 0-100 ppm (menu selectable)
	Ammonia NH₃ Output Scaling	0-100 ppm (default), 0-100 ppm (menu selectable)
	Temp Output Scaling (optional)	-20 to 85°C
Output (BACnet/Modbus)	RS-485	BACnet MS/TP, Modbus RTU, Modbus ASCII
	Baud Rates	9600, 19200, 38400, 57600, 76800, 115200
	RS-485 Loading	1/4 unit
Fan Relay	Fan relay (standard)	N.C. 1A@24VAC/30VDC(50/60Hz)(No Mains Connection)
	Fan relay (fail-open version)	N.O. 1A@24VAC/30VDC(50/60Hz)(No Mains Connection)
Alarm Relay	Alarm relay (standard)	N.C. 1A@24VAC/30VDC(50/60Hz)(No Mains Connection)
	Alarm relay (fail-open version)	N.O. 1A@24VAC/30VDC(50/60Hz)(No Mains Connection)
Display	3-1/2 digit LCD	Indicates CO ppm, NO ₂ ppm, Temp (menu selectable)
LED's	Green, Yellow, Red	Green = Normal, Yellow = Relay, Red = Alarm
Audible exposure alarm	85dB @4" Piezo transducer	30 minutes above alarm set-point per UL2075 (menu selectable)
CO Sensor Performance ⁽²⁾	Type	Electrochemical
	Accuracy	±5% of Default Range, ± 5% of Reading Above 200ppm
	Resolution	1 ppm
	Certifications	UL2075 Recognized component
	Life expectancy	7 years
	Recommended Calibration	Annual
NO ₂ Sensor Performance ⁽³⁾	Recommended Height⁽⁴⁾	3 to 6 feet; coverage 5000-7500 sq ft.
	Type	Electrochemical
	Accuracy	±5% of Default Range, ± 5% of Reading Above 20ppm
	Resolution	0.1ppm
	Certifications	UL2075 Recognized component
	Life expectancy	7years
	Recommended Calibration	Annual
	Recommended Height	3 to 6 feet; coverage 5000-7500 sq ft.

(1) One side of transformer secondary is connected to signal common. Dedicated transformer is recommended. No mains circuit connection allowed. In addition, it is required to use an isolated power supply that is certified by a national or international standard (i.e. UL). Use of a Class 2 LPS power supply or greater is required.

(2) Carbon Monoxide full scale is 1000 ppm.

(3) Nitrogen Dioxide full scale is 30 ppm.

SPECIFICATIONS (Part 2/3)

CO ₂ Sensor Performance	Type	Non-dispersive Infrared (NDIR)
	Accuracy ⁽⁴⁾	±(30ppm +3% of reading) (400-2000ppm), @-10-50°C
		±(50ppm +5% of reading) Standard (2000-5000ppm), @-10-50°C ±(50ppm+3% of reading) Dual Channel (2000-5000ppm), @-10-50°C ±(100ppm+10% of reading) (5000-10000ppm), @ 0-50C
	Drift with ABC disabled ⁽⁵⁾	35ppm/month ⁽⁶⁾ (Standard) 5ppm/month ⁽⁶⁾ (Dual Channel)
	Range	0-2000/5000ppm; Programmable up to 10,000ppm
	Resolution	1 ppm
	Life expectancy	15 years
	Response time	30s
	Sample rate	1s
Recommended Height	3 to 6 feet; coverage 5000-7500 sq ft.	

Methane/Propane/ Hydrogen Sensor Performance	Type	Catalytic
	Detection Range	0-50% LEL (Lower Explosive Limit)
	Accuracy	±5% of Range
	Resolution	1% LEL
	Certifications	UL2075 Recognized component for Methane/Propane
	Life expectancy	>5 years
	Response Time	<10s to 90%
	Recommended Calibration	Annual ⁽⁹⁾
	Long Term Stability Drift	Zero: <±2mV/year Sensitivity: <±2mV/month
	Recommended Height ⁽⁶⁾	Hydrogen/Methane: 0.5 to 1 foot from ceiling; coverage 5000-7500 Propane: 1-3 ft. above finished floor, coverage area 5000 sq. ft.

Oxygen Sensor Performance	Type	Electrochemical
	Detection Range	0-25% Volume
	Accuracy	±5% of Range
	Resolution	0.1%
	Life expectancy	5 years
	Recommended Calibration	Annual
Recommended Height	3 to 6 feet; coverage 5000-7500 sq ft.	

Hydrogen Sulfide (H ₂ S) Sensor Performance	Type	Electrochemical
	Detection Range	0-100 ppm
	Accuracy	±5% of Range
	Resolution	1 ppm
	Life expectancy	5 years
	Recommended Calibration	6 months
Recommended Height	3 to 6 feet; coverage 5000-7500 sq ft.	

Ammonia (NH ₃) Sensor Performance	Type	Electrochemical
	Detection Range	0-100 ppm
	Accuracy	±5% of Range
	Resolution	0.1 ppm
	Life expectancy	5 years
	Recommended Calibration	6 months
Recommended Height	0.5 to 1 foot from ceiling; coverage 5000-7500 sq ft.	

(4) CO₂ sensor is equipped with a heater to account for temperatures down to -40°C

(5) It is not recommended to de-activate ABC (auto-calibration) except for continuously occupied spaces or greenhouses. Drift ratings may vary based on environment.

(6) Combination CO/Methane, CO/Propane, or CO/Refrigerant sensors should be mounted according to Propane/Methane/Refrigerant recommendations. Consult factory for other combinations. Mounting height recommendations may be adjusted according to installation. Ensure sensor is accessible for maintenance and target gas has unobstructed access to sensor. Mount in accordance with ANSI/NFPA 70 and NEC or CEC.

SPECIFICATIONS (Part 3/3)

	Type	MOS
	Detection Range	0-1000 ppm
	Resolution	1 ppm
	R22, R134A, R410A, R404A, R407C	Calibrated for respective gas
Refrigerant Sensors Performance	R134A Sensitivity⁽⁷⁾	@300ppm test gas: 450 ppm R410A, 425 ppm R407C, 400 ppm R404A, 370 ppm R22, 300 ppm R134A
	Other Detectable Gases⁽⁸⁾	R407A, R407F, R427A, R452B, R507, R448A, R454B, R455A, R455C, R422A, R422D, R452A, R514A, R32, Consult factory for other A2L gases
	Life expectancy	10 years (typical expectation for MOS sensors)
	Recommended Calibration	6 months
	Recommended Height	6 inches above floor; no more than 18 inches above lowest level of equipment location for leak detection; coverage 5000-7500 sq ft.
Operating Environment	Temperature, continuous	-20 to 50°C (MOS rated down to -30°C; CO ₂ rated down to -40°C)
	Humidity	15-90% continuous, 0-99% intermittent
	Max Elevation	2000m
	Material	ABS/Polycarbonate
Enclosure (Wall & Duct)	Dimensions	4.0”h x 4.4”w x 2.1”d
	Conduit Opening	Tapped 1/2” NPT
	Rating	IP43 or NEMA 3R
	Material & Enclosure Rating	Powder-coated steel/acrylic
Enclosure (Metal)	Dimensions	5.0”h x 4.3”w x 2.25”d
	Opening	Dual air vents on bottom of enclosure
	Mounting	Pre-drilled for 2x4” electrical box
	Rating	IP41 or NEMA 3R
Agency	Compliance	UL61010-1 Listed UL, cUL, CE, UL2075 Recognized CO/NO ₂ /Propane/Methane sensors

(7) R134A sensor may be used as a general purpose refrigerant detection. The sensor's response to other refrigerants will change proportionally as shown in the following app note: <https://www.senvainc.com/catalog/documents/downloadcenter/Refrigerant%20cross%20sensitivities.pdf> (or scan QR code). Actual response may vary depending on installation. For more accurate response to a specific gas, a unit may be field calibrated.

(8) These gases may be detected by the sensor but sensitivity curves are not available at this time.

(9) It is recommended to perform an annual bump test of the sensor to ensure it is reading gas as expected and that the sensor has not been poisoned or damaged.



TROUBLESHOOTING

Symptom	Solution
No output	Check wiring. Ensure power supply meets requirements.
Sensor reading error	Sensor contaminated or at end of life. Replace sensor.
Relay Function	Verify set-point. Verify test gas concentration. Cover sensor to prevent drafts and dilution during test.
LCD readout error	See TG Series User's Guide for full list of LCD diagnostic code definitions.
Chirping Noise	Reliability feature has detected a faulty or missing sensor. Replace sensor element.
Refrigerant Sensor Unstable at Installation	Refrigerant sensors require 1-3 hours of runtime post-installation for the value to stabilize and lower.

DIMENSIONS

TGW

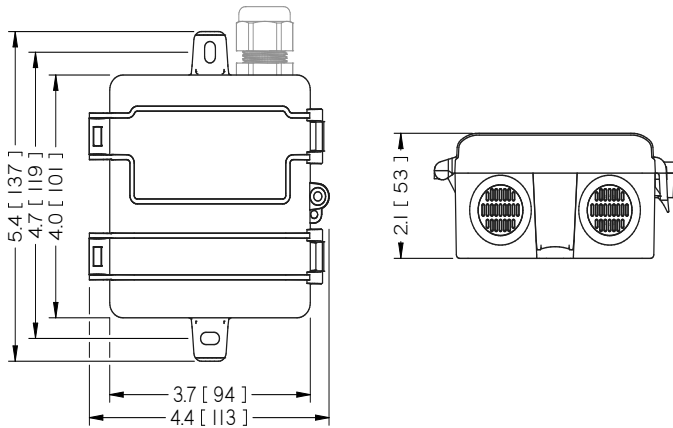

TGM Base

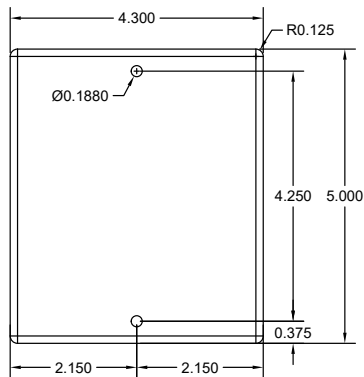

TGM Lid

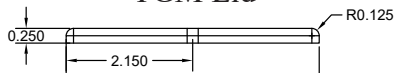

TGM Bottom View

