

# INSTALLATION INSTRUCTIONS

## HT0D Economy Series Duct RH Transmitters



### IMPORTANT WARNINGS

- Only qualified trade installers should install this product
- This product is not intended for life-safety applications
- Do not install in hazardous or classified locations
- The installer is responsible for all applicable codes
- De-energize power supply prior to installation or service

### PRODUCT APPLICATION LIMITATION:

Senva products are not designed for life or safety applications. Senva products are not intended for use in critical applications such as nuclear facilities, human implantable device or life support. Senva is not liable, in whole or in part, for any claims or damages arising from such uses.

### DIMENSIONS

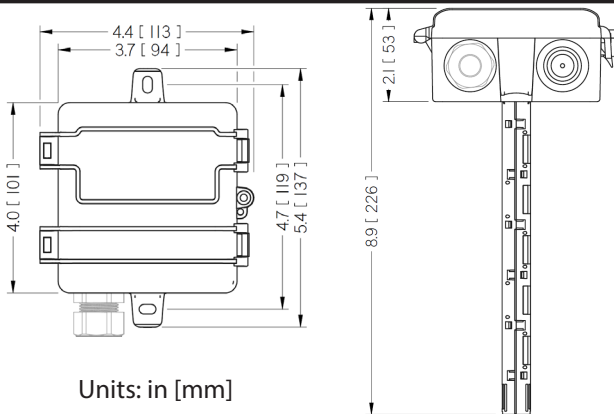

Units: in [mm]

### CALIBRATION

Senva RH sensors are factory calibrated. No field calibration is necessary or recommended.

### TROUBLESHOOTING

Symptom	Solution
No output	Check wiring. Ensure power supply meets requirements.
Temp or RH reading error	Verify control panel software is configured for correct output scaling.
	Verify accuracy of test instrument. Observe installation guidelines
	Verify unit is located away from sources of hot/cold.
	Install insulation foam gasket provided to prevent thermal conduction from inside wall.

### INSTALLATION

1. Drill a 3/4" hole in duct. Install sensor using gasket and screws provided. The pickup tube will ensure adequate air flow regardless of air flow direction.
2. If installing with a conduit adapter, remove and replace the factory-installed cable gland.
3. Wire sensor as shown.

#### 3-wire:

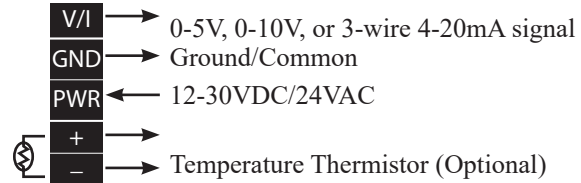

#### 2-wire:

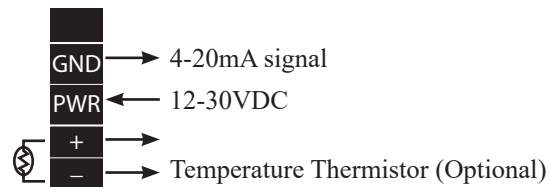

5. Apply power to sensor.
6. Tighten cable gland firmly around wires. If installing with a conduit adapter, seal wire entry to prevent conduit air from affecting sensor readings or operation.
7. Close lid and tighten screw. Cover must be securely installed to prevent moisture from entering enclosure.

## SPECIFICATIONS

Power supply		12-30VDC/24VAC <sup>(1)</sup> 24mA max power consumption
Outputs	RH	2-wire 4-20mA, 3-wire 4-20mA, 0-5V, 0-10V <sup>(4)</sup> (Optional)
Output scaling	RH	0-100%RH
Thermistor/RTD options		Yes, see ordering table in catalog
Relative Humidity	Accuracy	2% models: $\pm 2\%$ max 0 to 100% RH
		3% models: $\pm 3\%$ max 0 to 100% RH
	Resolution	0.01%RH
	Hysteresis	$\pm 0.8\%$ RH
	Repeatability	0.08% RH
	Non-linearity	Factory linearized <1%RH
	Temperature coefficient	Fully compensated by on-board sensor
	Response time <sup>(2)</sup>	8s
	Output update rate	0.5s
	Operating range	0 to 100%RH (non-condensing)
	Long term drift	<0.25%RH per year
	Element Recommended Operating conditions <sup>(3)</sup>	41 to 140°F (5 to 60°C) @ 20% to 80% RH
	Environmental	Enclosure Rating
Unit Temp Rating		-40°F to 158°F (-40 to 70°C)

(1) One side of transformer secondary is connected to signal common. Dedicated transformer is recommended. No VAC power connection on two wire devices.

(2) Time for reaching 63% of reading at 25°C and 1 m/s airflow.

(3) Long term exposures to conditions outside normal range or high humidity may temporarily offset the RH reading (+3%RH after 60 hours.)